

- I** Bruciatore a biocombustibile
- GB** Biofuel burner
- F** Brûleur à biocombustible
- D** Brenner mit Brennstoffen
- E** Quemador de biocombustible

Funzionamento monostadio
One stage operation
Fonctionnement à 1 allure
Einstufiger Betrieb
Funcionamiento a 1 llama

CODICE - CODE CÓDIGO	MODELLO - MODEL - MODELE MODELL - MODELO	TIPO - TYPE - TYP
20206787	RG4S B100	396 T1

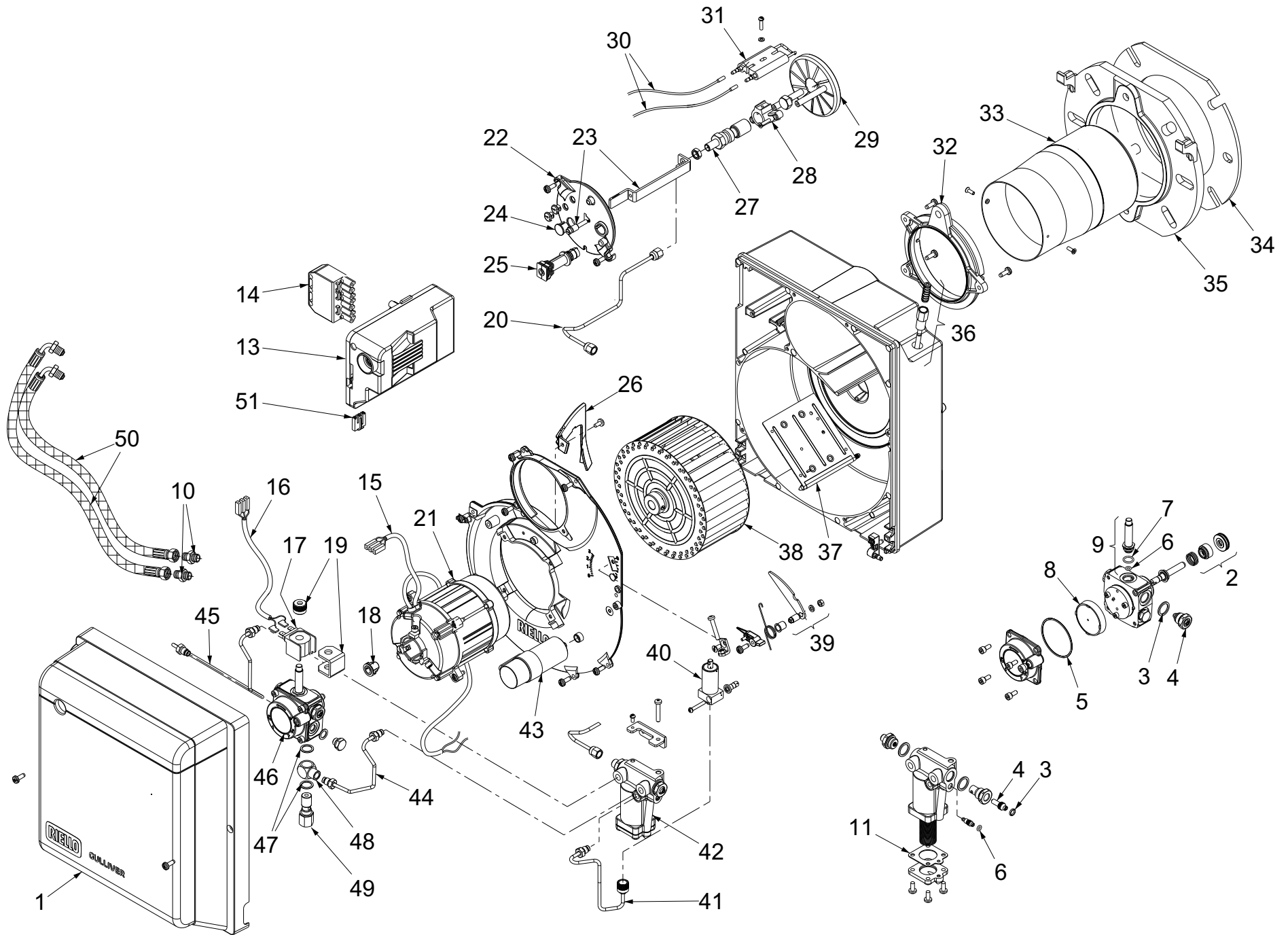

N.	COD.	DESCRIZIONE	DESCRIPTION	DESCRIPTION	BESCHREIBUNG	DENOMINACION	MATRICOLA BRUCIATORE BURNER SERIAL NUMBER MATRICULE BRULEUR BRENNER KENN-NUMMER MATRICULA QUEMADORES	*
1	3008496	COFANO	COVER	CAPOT	VERKLEIDUNG	TAPA		B
2	3007612	ORGANO DI TENUTA	PUMP SEAL	ORGANE D'ETANCHEITE	DICHTUNGSEINSATZ ANTRIEBSWELLE	CONJUNTO ESTANQUIDAD		A
3	3007028	ANELLO OR	O-RING	JOINT TORIQUE	O-RING-DICHTUNG	JUNTA TÓRICA		B
4	3007583	REGOLATORE	REGULATOR	REGULATEUR	REGLER	REGULADOR		C
5	3007175	ANELLO OR	O-RING	JOINT TORIQUE	O-RING-DICHTUNG	JUNTA TÓRICA		B
6	3007177	ANELLO OR	O-RING	JOINT TORIQUE	O-RING-DICHTUNG	JUNTA TÓRICA		B
7	3007872	ANELLO OR	O-RING	JOINT TORIQUE	O-RING-DICHTUNG	JUNTA TÓRICA		B
8	3005719	FILTRO	FILTER	FILTRE	FILTER	FILTRO		B
9	3007871	VALVOLA	NEEDLE VALVE	VANNE MAGNETIQUE	NADELVENTIL	VALVULA		B
10	3003602	RACCORDO	CONNECTOR	MAMELON	NIPPEL	RACORD		C
11	3005801	GUARNIZIONE	SEAL	JOINT	DICHTUNG	JUNTA		B
13	20169017	CONTROLLO FIAMMA	FLAME CONTROL	BOÎTE DE CONTRÔLE	STEUERGERÄT	CAJA DE CONTROL		B
14	3006937	SPINA 7 POLI	7 PIN PLUG	FICHE 7 PÔLES	7-POLIGER STECKER	CONECTOR MACHO DE 7 CONTACTOS		A
15	3007454	PRESA MOTORE	MOTOR SOCKET	PRISE MOTEUR	STECKDOSE FÜR MOTOR	CONECTOR MOTOR		
16	3007772	COLLEGAMENTO	CONNECTION	CONNEXION	VERBINDUNG	CONEXIÓN		A
17	3007565	BOBINA	COIL	BOBINE	SPULE	BOBINA		B
18	3000443	GIUNTO	JOINT	ACCOUPLLEMENT	PUMPENKUPPLUNG	ACOPLAMIENTO		A
19	3007566	MANTELLO E POMELLO	SHELL AND KNOB	ETRIER ET ECROU	HALTEBÜGEL MIT SCHRAUBE	PROTECCIÓN BOBINA		
20	3007869	TUBO	TUBE	TUYAU	RÖHRCHEN	TUBO		C
21	20214136	MOTORE	MOTOR	MOTEUR	MOTOR	MOTOR		C
22	3007642	COPERCHIO	COVER	COUVERCLE	DECKEL	TAPA		
23	3007644	STAFFA	BRACKET	SUPPORT	HALTEBLECH	SOPORTE		
24	3007458	VETRINO	VIEWING PORT	REGARD	VERSCHLUßSTOPFEN	MIRILLA		
25	20135304	SENSORE FIAMMA	FLAME SENSOR	CAPTEUR FLAMME	FLAMMENFÜHLER	SENSOR LLAMA		A
26	3007651	CONVOGLIATORE	SUCTION DUCT	CONVOYEUR D'AIR	LUFTLEITBLECH	GUÍA		
27	3007496	PORTAUGELLO	NOZZLE HOLDER	PULVERISATEUR	DÜSENSTOCK	PORTABOQUILLA		C
28	3007466	SUPPORTO	SUPPORT	SUPPORT	HALTER	SOPORTE		A
29	3007645	DIFFUSORE	DIFFUSER	DIFFUSEUR	GAS VERTEILER	DIFUSOR		
30	3002324	COLLEGAMENTO ELETTRODO	ELECTRODE CONNECTION	CONNEXION ELECTRODE	ELEKTRODEVERBINDUNG	CONEXIÓN ELECTRODO		A
31	3007495	GRUPPO ELETTRODI	ELECTRODE ASSEMBLY	GROUPE ELECTRODES	ELEKTRODENBLOCK	CONJUNTO ELECTRODOS		
32	3007646	COLLARE	COLLAR	COLLIER	BRENNERFLANSCH	COLLARÍN		
33	3007868	BOCCAGLIO	BLAST TUBE	GUEULARD	FLAMMROHR	TUBO LLAMA		B
34	3005813	SCHERMO	FLANGE GASKET	ECRAN THERMIQUE	KESSELFLANSCH-DICHTUNG	JUNTA AISLANTE		A
35	3005814	FLANGIA	FLANGE	BRIDE	KESSELFLANSCH	BRIDA		
36	3007648	REGOLATORE SERRANDA ARIA	AIR DAMPER REGULATOR	SYSTEME REGLAGE D'AIR	LUFTREGULIERUNG	REGULADOR REGISTRO AIRE		
37	3007650	SERRANDA ARIA	AIR DAMPER	VOLET D'AIR	LUFTKLAPPE	REGISTRO DEL AIRE		
38	3007652	GIRANTE	FAN	TURBINE	GEBLÄSERAD	TURBINA		C
39	3008567	REGOLATORE SERRANDA ARIA	AIR DAMPER REGULATOR	SYSTEME REGLAGE D'AIR	LUFTREGULIERUNG	REGULADOR REGISTRO AIRE		

N.	COD.	DESCRIZIONE	DESCRIPTION	DESCRIPTION	BESCHREIBUNG	DENOMINACION	MATRICOLA BRUCIATORE BURNER SERIAL NUMBER MATRICULE BRULEUR BRENNER KENN-NUMMER MATRICULA QUEMADÓRES	*
40	20173358	MARTINETTO	HYDRAULIC JACK	VERIN AIR	DRUCKKOLBEN FÜR LUFT- KLAPPE	HIDRÁULICO DEL AIRE		C
41	3007783	TUBO	TUBE	TUYAU	RÖHRCHEN	TUBO		C
42	20035202	RITARDATORE IDRAULICO	HYDRAULIC DELAYNG DEVICE	RETARDATEUR HYDRAULIQUE	STARTVERZÖGERER	RETARDADOR HIDRÁULICO		C
43	20087037	CONDENSATORE	CAPACITOR	CONDENSATEUR	KONDENSATOR	CONDENSADOR		C
44	3007780	TUBO	TUBE	TUYAU	RÖHRCHEN	TUBO		C
45	3007788	TUBO	TUBE	TUYAU	RÖHRCHEN	TUBO		C
46	3007810	POMPA	PUMP	POMPE	PUMPE	BOMBA		C
47	20122674	GUARNIZIONE	SEAL	JOINT	DICHTUNG	JUNTA		B
48	3005805	RACCORDO	CONNECTOR	MAMELON	NIPPEL	RACORD		C
49	3005804	PERNO	BAR	GLISSIERE	BOLZEN	PERNO		C
50	3007609	TUBO FLESSIBILE	HOSE	TUYAU FLEXIBLE	ÖLSCHLAUCH	TUBO FLEXIBLE		A
51	3007792	PRESA DI CORTOCIRCUITO	SHORT CIRCUIT PLUG	PRISE DE COURT CIRCUIT	BRÜCKENSTECKER	TOMA CORTOCIRCUITO		

*

RICAMBI CONSIGLIATI - ADVISED PARTS - RECHANGE CONSEIL - EMPFOHLENE ERSATZTEILE - RECAMBIOS ACONSEJADOS

A = Ricambi per dotazione minima - Spare parts for minimum fittings - Pièces détachées pour équipement minimum - Ersatzteile für minimale Ausstattung - Recambios para equipamiento mínimo

A+B = Ricambi per dotazione base di sicurezza - Spare parts for basic safety fittings - Pièces détachées pour équipement standard de sécurité - Ersatzteile für Sicherheitsgrundausrüstung - Recambios para equipamiento básico de seguridad

A+B+C = Ricambi per dotazione estesa di sicurezza - Spare parts for extended safety fittings - Pièces détachées pour équipement complet de sécurité - Ersatzteile für erweiterte Sicherheitsausstattung - Recambios para equipamiento general de seguridad

RIELLO

RIELLO S.p.A.
I-37045 Legnago (VR)
Tel.: +39.0442.630111
[http:// www.riello.it](http://www.riello.it)
[http:// www.riello.com](http://www.riello.com)